



## TECNOLOGIA PURA A 24 CARATI 24-CARAT TECHNOLOGY

*Il "carato" indica la misura della "purezza". Quantifica le parti di una lega su base 24/24esimi. Nel caso delle leghe d'oro, un "carato" equivale ad una parte su un totale di 24 parti. La massima purezza è dunque a 24 carati (24 parti d'oro su 24 totali) e si indica con la sigla 24Kt. Carato, in arabo "qi-ra-t" che significa infatti la 24ª parte. In greco classico invece "keration" (carato) indicava il seme della carruba, che, incredibile a dirsi, pesa quasi sempre 0,2 g cioè un carato, cioè l'indice che misura il peso dei diamanti. Oro, diamanti, sono tra le cose più preziose che la natura ci offre. La nostra KT24 è il nuovo gioiello di Orion.*

*A "carat" indicates the measure of "purity". It quantifies the parts of an alloy on a base of 24/24th. In the case of gold alloys, a "carat" corresponds to one part on a total of 24 parts. The maximum purity is then with 24 carats (24 parts of gold on a total of 24) and you indicate it through the abbreviation 24Kt. Carat, in Arabic "qi-ra-t", that means indeed 24th part. On the contrary, the classical Greek word "keration" (carat) indicated the carob seed, that, incredibly, almost always weighs 0.2 g, i.e. one carat, i.e. the index that measures the weight of diamonds. Gold, diamonds: they are among the most precious things that nature offers us. Our KT 24 is the new jewel by Orion.*



*COLOUR,  
CLARITY,  
CUT AND CARAT:  
LE 4 CARATTERISTICHE  
DI UN DIAMANTE  
PERFETTO*

*COLOUR, CLARITY, CUT AND CARAT:  
4 CHARACTERISTICS OF A PERFECT DIAMOND.*







# COLOUR LA LUCE CHE ESALTA LA FORMA

ILLUMINAZIONE A LED.

*COLOUR. THE LIGHT THAT EXALTS  
THE SHAPE. LED LIGHTING.*













# CUT LA FORMA PURA

LINEE ESSENZIALI CONTEMPORANEE A ELEVATA ERGONOMIA.

*CUT. THE PURE SHAPE.  
HIGH ERGONOMIC CONTEMPORARY ESSENTIAL LINES.*





COLOUR  
CLARITY  
CUT  
CARAT









# CLARITY LA TRASPARENZA CHE SEDUCE

NON CI SONO PARTI CHE OSTACOLANO LA VISIBILITÀ  
DEL PRODOTTO, GRAZIE ANCHE A UNA STRUTTURA UNICA  
IN PLEX AD ALTO SPESSORE.

*CLARITY. SEDUCTIVE TRANSPARENCY.  
THERE AREN'T PARTS THAT PREVENT THE PRODUCT  
VISIBILITY, THANKS ALSO TO A SINGLE STRUCTURE  
OF HIGH THICKNESS PLEXIGLAS.*









# CARAT LA DIMENSIONE DELLA TECNOLOGIA

GRANDI PRESTAZIONI E LA GAMMA PIÙ COMPLETA.

*CARAT. THE DIMENSION OF TECHNOLOGY.  
GREAT PERFORMANCE AND THE MOST COMPLETE RANGE.*



## KT24

SEZIONE SECTION  
H 1360

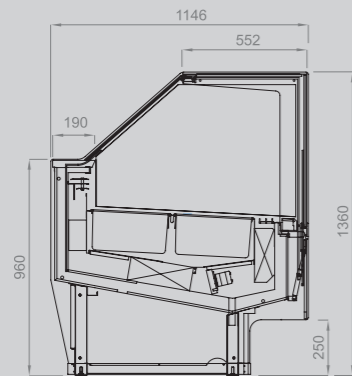

SEZIONE SECTION  
H 1160

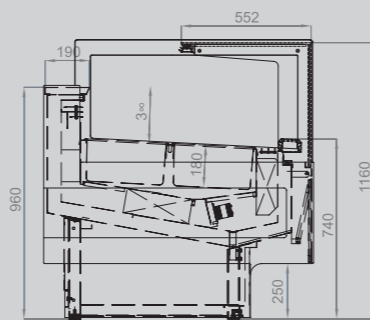

## MODULI ANGOLARI / CORNER MODULES

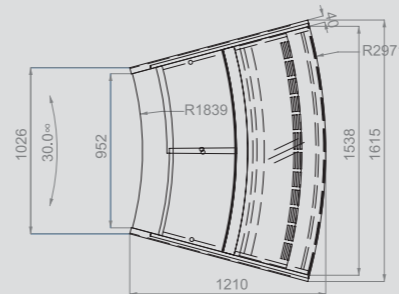

KT24 RVS • A30 • H 1160

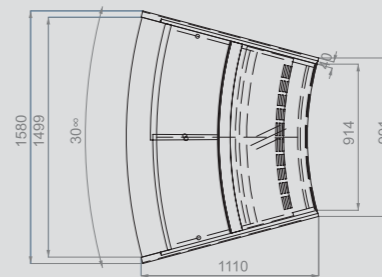

KT24 RVS • A30 • H 1160

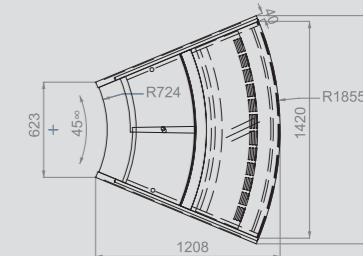

KT24 RVS • A45 • H 1160

## KT24 CON MENSOLE / KT24 WITH SHELVES

SEZIONE SECTION  
H 1360

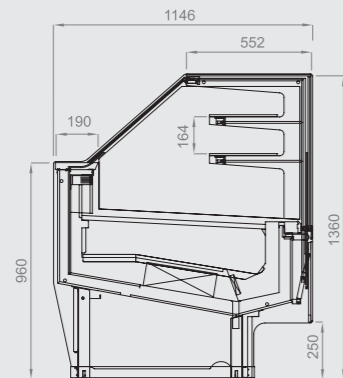

SEZIONE SECTION  
H 1160

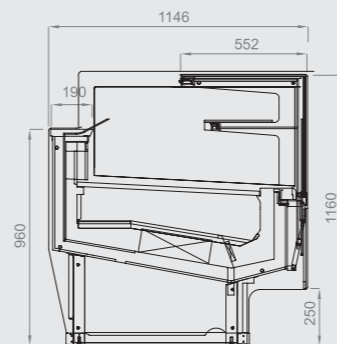

## MODULI LINEARI / LINEAR MODULES

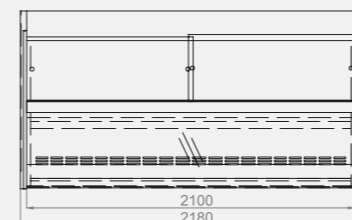

MODULO / MODULE 4M

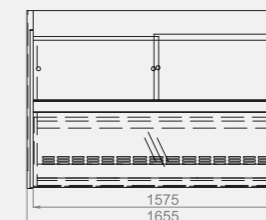

MODULO / MODULE 3M

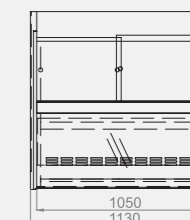

MODULO / MODULE 2M

## ALLESTIMENTO VASCHETTE GELATO / ICE CREAM TUBS

numero vaschette da 360 x 165 mm  
number of tubs with dimensions 360 x 165 mm

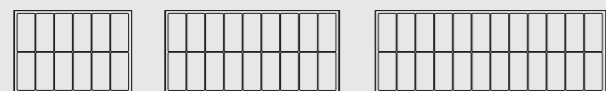

G6

G9

G12



C30°

A30°

A45°

numero vaschette da 360 x 250 mm  
number of tubs with dimensions 360 x 250 mm

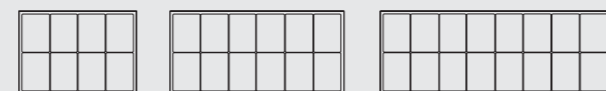

G6

G9

G12



C30°

A30°

A45°

## TABELLA DI RIEPILOGO PER L'IDENTIFICAZIONE DELLE FUNZIONI PER CIASCUNA DIMENSIONE (IN CM) DISPONIBILE COMPARATIVE TABLE TO IDENTIFY THE FUNCTIONS FOR AVAILABLE DIMENSIONS IN CM (CENTIMETERS)

GAMMA RANGE	LUNGHEZZE LENGTHS (u.m. mm)	GELATO ICE-CREAM	PASTICCERIA VENTILATA PASTRY W. VENTILATED REFRIGERATION	PASTICCERIA VENTILATA CON CASSETTI PASTRY W. VENTILATED REFRIGERATION WITH STORAGE	PASTICCERIA NEUTRA O STATICA NEUTRAL PASTRY OR W. STATIC REFRIGERATION	PRALINE PRALINE	SNACK FREDDO COLD SNACK	SNACK CALDO secco-umido WARMED SNACK dry-humide warmed
2M/G6	1100	•	•	•	•	•	•	•
3M/G9	1600	•	•	•	•	•	•	•
4M/G12	2100	•	•	•	•	•	•	•
angolo aperto open angle	A 30°	•	•					
angolo chiuso closed angle	C 30°	H1350 •	H1160 •					
angolo aperto open angle	A 45°	•	•					



I colori, le tonalità e le finiture dei prodotti contenuti in questo catalogo possono presentare sensibili variazioni dall'originale a causa dei limiti grafici e di stampa. Orion si riserva di apportare modifiche tecniche e funzionali ove ritenesse necessario al fine di migliorare i propri prodotti e la soddisfazione del cliente.

*Colours, shades and finish of all products contained in this catalogue can present sensible variations compared to the original ones due to graphic and press limits. Orion reserves to introduce technical and functional changes where deemed necessary in order to improve its own products and its clients' satisfaction.*

Hanno collaborato alla realizzazione di questo catalogo  
Have contributed to making this brochure

office research & development  
CLABO GROUP

design  
ANDREA STRAMIGIOLI

art direction  
MARCO MASSALINI - LIFE

graphic design  
LIFE

potography  
GIORGIO TREBBI - LIFE

styling  
PAOLA MOTOLESE L.

copy  
DAVIDE ROCCETTI

color separation  
IMMAGINE E COLORE

print  
MANSERVIGI



ORION marchio di **CLABO GROUP** Spa  
ZIPA - Viale dell'Industria  
60035 Jesi (Ancona) Italy  
Tel. +39 0731 61531  
Fax +39 0731 6153427  
[www.orionstyle.com](http://www.orionstyle.com)  
[infoweb@orionstyle.com](mailto:infoweb@orionstyle.com)